

**New Product** This is best to prevent slug pulling for large station

**Die cutting edge 「All Taper II」**

~Best for a punching machine with slug vacuum function~

High Quality & Technology For The Future

**CONIC**

**NEWS**

**The point is Two-Stage Shape of Taper.**

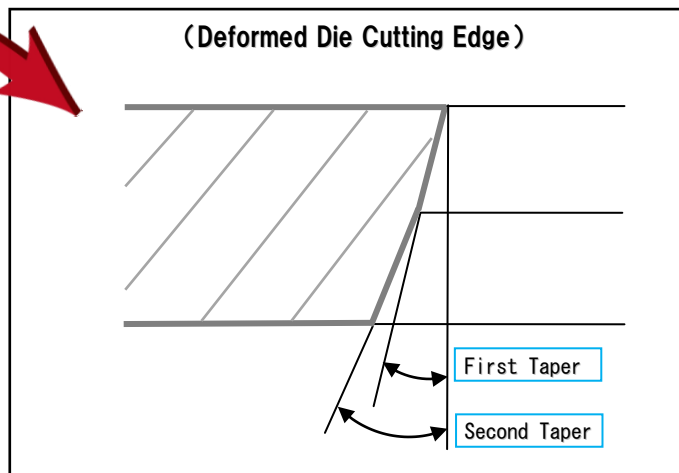

This die cutting edge is suitable for a punching machine with slug vacuum function, which discharges punched slug strongly to scrap boxes. This die maximizes slug suction function and prevents slug pulling for large station.

■Compatible with

Amada Type Thick Turret Tooling : Z turret / Punching machines with slug vacuum function such as EM.  
(included same diameter turret)

Murata Type Tooling : Punching machines with slug vacuum function.



■Note

This punch press tool demonstrates best performance by setting slug vacuum function to ON. If you set to OFF and use it, the burden on the compressor will be reduced but the effect of slug pulling prevention will be decreased greatly.

When you do not use slug vacuum function, we recommend our standard "slug catcher cutting edge(SC)".

■Suggestion

If you use punching machines with slug vacuum function, please let us know once. We will inform you of "the most suitable blade specification for your company" at the time of ordering and requesting quotation afterwards.

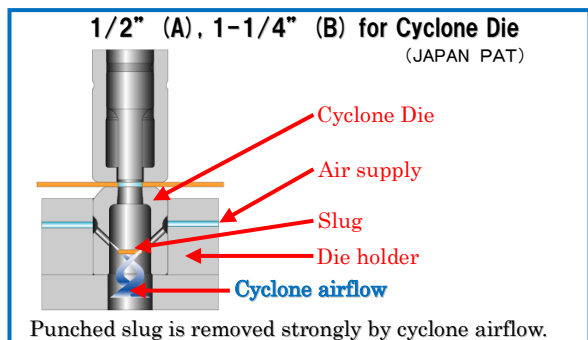

**CONIC Co., Ltd.**

TEL.+81-868-38-6154

FAX.+81-868-38-6331

E-mail: tools@conic.co.jp

URL: <http://www.conic.co.jp/EnPage/index.html>