

Revolution in preparing press brake processing

~Eco Clamp~

High Quality & Technology For The Future
CONIC

NEWS

Straight/Drop protection/One touch Compatible with every type !

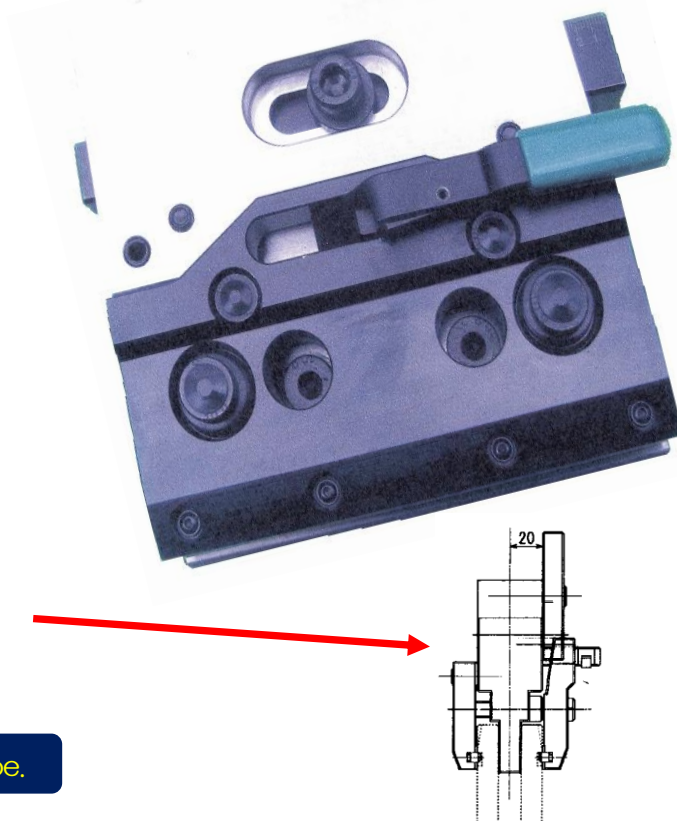
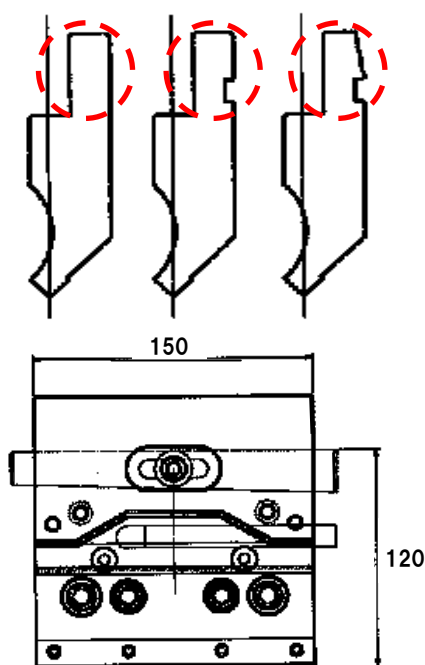

Eco Clamp is only for Machine Table Z II type.

Machine Table Z II : The distance from the center point of bending tool to the reference plane is 20mm.

Machine Table Z I : The distance from the center point of bending tool to the reference plane is 7 mm.

KOMATSU TYPE

Good news for customers who use
AMADA tools with KOMATSU machines.

Length : 150mm

CONIC Co., Ltd.

TEL.+81-868-38-6154

FAX.+81-868-38-6331

E-mail: tools@conic.co.jp

URL: <http://www.conic.co.jp/EnPage/index.html>