

Revolution in preparing press brake processing

~One touch die holder~

High Quality & Technology For The Future
CONIC

NEWS

[Good points]

- ▼ You can lock all tools of the holder with only one lever.
- ▼ Regardless of length it can lock die at any position and maintains the condition after centering.
- ▼ There is no positional deviation even for short molds and it is ideal for accurate sheet metal processing.
- ▼ It can be used putting side by side with conventional holders.
- ▼ The lever is removable.

Cost reduction by
reconsidering
preparation of press
brake processing.

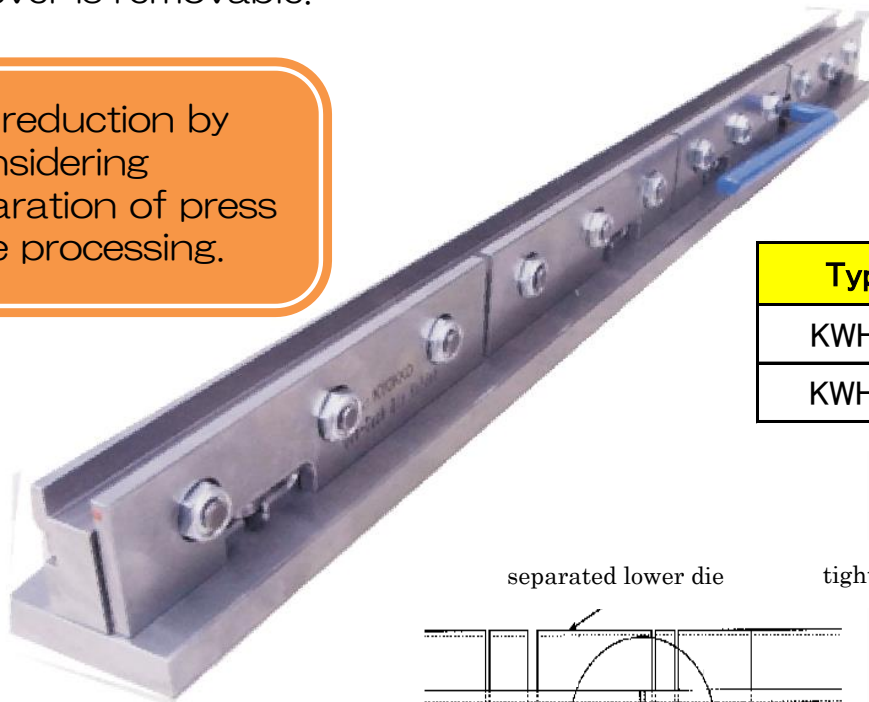

Type	Length
KWH-L	835mm
KWH-S	415mm

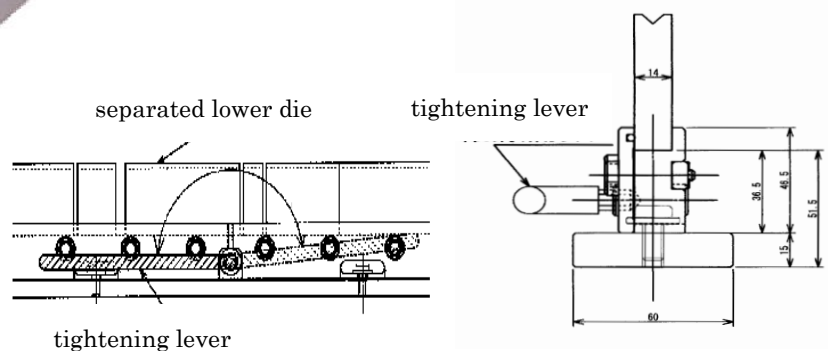

We have a large assortment of
tools for press brake
(standard/special).

Please feel free to contact us.

CONIC Co., Ltd.

TEL.+81-868-38-6154

FAX.+81-868-38-6331

E-mail: tools@conic.co.jp

URL: <http://www.conic.co.jp/EnPage/index.html>